

PRODUCT DATASHEET

ORION S40

FASTCAM series by Photron



FASTCAM Orion S40

1.3-Megapixel CMOS BSI¹ Image Sensor with CDS²:
1280 x 1024 pixels at 31,250fps

Maximum Frame Rate:

312,500fps (Orion S40 type 312K)
200,000fps (Orion S40 type 200K)

Class Leading Light Sensitivity:

ISO 40,000 monochrome
ISO 10,000 color

Global Electronic Shutter:

1.0 μ s independent of frame rate.

Dynamic Range (ADC):

12-bit

Compact and Lightweight:

267mm (H) x 182mm (W) x 93.6mm (D)
10.5" (H) x 7.2" (W) x 3.7" (D)
Weight: 4.07kg (10.4 lbs.)

Internal Recording Memory:

32GB, 64GB, 128GB

- 1 Back Side Illuminated
- 2 Correlated Double Sampling

HIGH-QUALITY, HIGH-SPEED CAMERA WITH ULTRA-LOW NOISE

The FASTCAM Orion S40 is the world's first high-speed camera to simultaneously implement both BSI (Back Side Illumination) and CDS (Correlated Double Sampling), significantly reducing temporal dark noise for improved black level resolution and dynamic range, thereby benefitting users processing images for PIV (Particle Image Velocimetry), DIC (Digital Image Correlation) and other specialized applications.

A 1.3 megapixel sensor operates up to 31,250fps with a 1.0 μ sec, minimum exposure and maximum recording rate up to 312,500fps.

Standard features of the FASTCAM Orion S40 include an internal mechanical shutter to allow remote system calibration, a high-performance 10-Gigabit Ethernet interface for camera control and high-speed image download, memory segmentation that allows recording into one memory partition while downloading from another, and compatibility with a number of industry standard lens formats to allow the use of Nikon G-Type, C-mount and Canon EF lenses. EF support includes software control of focus and aperture and auto-focus function.

Intuitive and feature rich Photron FASTCAM Viewer (PFV) software is included with the FASTCAM Orion S40 camera. Also included is a Photron Device Control SDK that allows integration of the camera with user-specific software, and libraries for controlling the camera within MATLAB or LabView environments.

Light Sensitivity:

FASTCAM ORION

Monochrome models	ISO 40,000
Color models	ISO 10,000

Monochrome sensors used in the FASTCAM Orion S40 are supplied without an IR absorbing filter, extending the camera spectral response beyond 900nm. When the sensitivity of the FASTCAM Orion S40 is measured to tungsten light including near IR response an equivalent value of ISO 100,000 is obtained.

A 16-micron pixel pitch gives a sensor size at full image resolution of 20.48 x 16.384mm (diagonal 26.23mm). Lenses designed for both FX (35mm full frame) and also DX (APS-C digital SLR) formats are fully compatible with the FASTCAM Orion S40 at full image resolution.

Sensor Type	Proprietary Design Advanced CMOS
Maximum Resolution (pixels)	1280 x 1024 pixels
Sensor Size / Diagonal	20.48 x 16.384mm / 26.23mm
Pixel Size (microns)	16µm square pixel
BSI (Back Side Illumination)	Yes
CDS (Correlated Double Sampling)	Yes
Temporal Dark Noise	7.2e-
Quantum Efficiency	57.5% @ 490nm
Fill Factor	TBD
Color Matrix	Bayer CFA (single sensor)
Light Sensitivity	ISO 40,000 monochrome ISO 10,000 color
Shutter	Global Electronic Shutter 1.0µs independent of frame rate

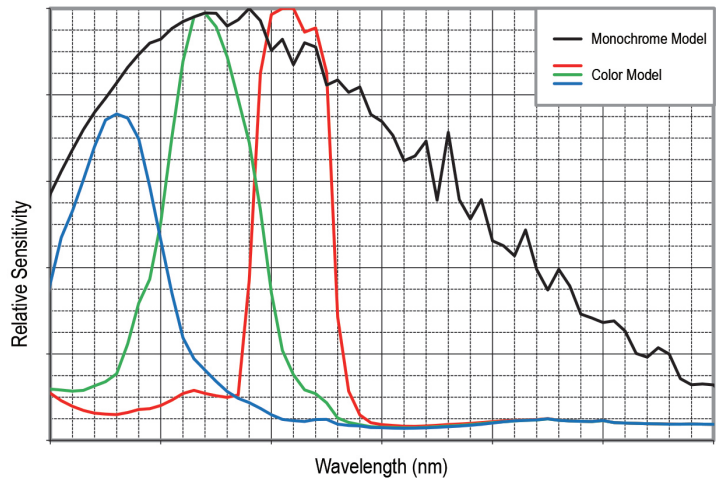

CDS function (Correlated Double Sampling)

With CDS, the reset noise value is measured – on a pixel-by-pixel basis – for each frame and then subtracted from the overall data level associated with a given exposure. By subtracting the reset noise level from the data level, the impact of that reset noise can be significantly reduced.

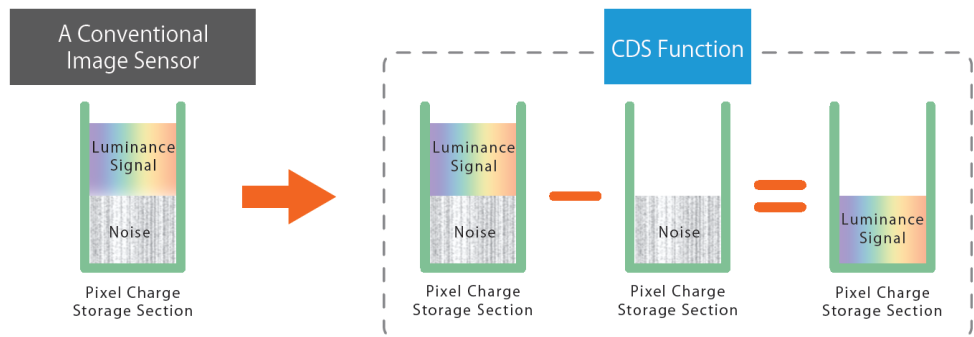

Specifications subject to change.

Back Side Illumination (BSI) sensor

By positioning the photodiode layer directly below the color filter array, BSI sensors allow light to directly reach the photosensitive area of the pixels. The incoming photons are not blocked by circuitry and wiring. This leads to enhanced light collection and greater light sensitivity.

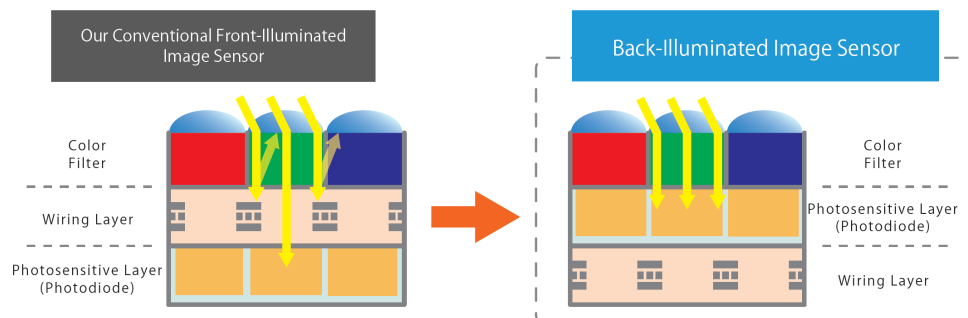

Camera Performance Specifications

Model	FASTCAM ORION S40
Full Frame Performance	31,250fps 1280 x 1024 pixels
Dynamic Range (ADC)	12-bit monochrome 36-bit color
Maximum Frame Rate	312,500fps* (896 x 32)
Light Sensitivity	ISO 40,000 monochrome, ISO 10,000 color
Minimum Exposure Time	Global electronic shutter to 1.0μsec, selectable independent of frame rate
Ruggedized Mechanical Calibration Shutter	Standard feature
Memory Capacity Options	32GB, 64GB, 128GB
Memory Partitions	Up to 128 memory segments
Region of Interest	Selectable in steps of 128 pixels (horizontal) x 16 pixels (vertical)
Trigger Inputs	Selectable TTL (+/- 5V) and Switch (NO or NC)
Trigger Delay	Programmable on selected input / output triggers: 100ns resolution
Input / Output	Input 1 to 3: Trigger (TTL/Switch), Sync, Ready, Event, TRIG, SW IN, IRIG IN Output 1 to 3: Trigger, Sync, Ready, Rec, Exposure, IRIG OUT
Trigger Modes	Start, Center, End, Manual, Random Rest, Random Manual
Time Code Input	IRIG-B (selectable at beginning or end of frame exposure)
External Sync	+3.3 to +12 V, negative polarity / positive polarity (switchable)
Camera Control Interface	RJ45 (10GBASE-T Only)
Image Data Display	Frame rate, resolution, shutter speed, trigger mode, date/time, status, real time / IRIG time, frame count
Saved Image Formats	BMP, TIFF, JPEG, PNG, RAW, MRAW, GRAW, AVI, MOV
Supported OS	Microsoft Windows 10/11 Pro, Enterprise, Education 64-bit

* Frame rates above 225,000fps and exposure times below 1μs may be subject to export control regulations in some areas

High-Speed 10-Gigabit Ethernet Interface:

The FASTCAM Orion S40 camera system is equipped with a high-speed 10-Gigabit Ethernet Interface to provide reliable camera control and fast download of image data.

Dedicated I/O:

Direct BNC connections provide three programmable inputs and three programmable outputs for common tasks such as triggering and synchronization of multiple cameras in conjunction with Data Acquisition (DAQ) hardware.

Ruggedized Mechanical Calibration Shutter:

The ruggedized mechanical shutter fitted as standard to the FASTCAM Orion S40 camera allows sensor black balance calibration to be carried out remotely from the system control software.

Optional C-Mount and Canon EF Lens Mounts:

In addition to the standard Nikon G type lens adapter, all FASTCAM Orion S40 models support an optional C-mount lens adapter and an optional Canon EF lens adapter which, through Photron FASTCAM Viewer (PFV), not only enables remote operation of lens focus and aperture but also adds Auto-Focus capability.

Camera Operation Features

Frame Synchronization	Accurate frame synchronization with other cameras and with external and unstable frequencies.
Memory Partitions	Up to 128 memory segments allow multiple events to be stored in camera memory before downloading, with automatic progression to the next available partition.
Low Light Mode	Operation at minimum frame rate with separately adjustable shutter time to allow easy camera set-up and focus in ambient lighting.
IRIG Phase Lock	Enables multiple cameras to be synchronized together with other instrumentation equipment or to a master external time source.
Internal Time Delay Generator	Allows programmable delays to be set on input and output triggers; 100ns resolution.
Event Markers	Up to ten user-entered event markers to define specific events within the recorded image sequence .
Download While Recording	FASTCAM Orion supports Partition Recording Mode, allowing image data captured in one memory partition to be downloaded while at the same time recording into another partition.
Automatic Download	The system can be set to automatically download image data to the control PC and, when download is complete to re-arm in readiness for the next trigger with automatically incremented file names.
Software Binning	Virtual pixel binning (2x2, 4x4 etc.) allows increased light sensitivity with reduced image resolution without changing camera field of view.

Operation Software Features

Image Calibration	2D image calibration allows the measurement of distance and angle from the image. A calibration grid overlay can be superimposed on the image.
Image Overlay	A stored reference image may be overlaid on the live image to allow accurate camera positioning to achieve the same view as a previous test.
Import of Multiple Image Sequences	Multiple image sequences can be loaded and simultaneously replayed. Timing of image sequences can be adjusted to create a common time reference. Time based synchronization allows images captured at different frame rates to be synchronized.
High Dynamic Range Mode	Making use of the full sensor dynamic range, HDR mode allows enhanced detail in both light and dark areas of an image to be displayed simultaneously.
Background Subtraction	In order to highlight subtle changes in an image, Background Subtraction allows a reference image to be subtracted from a recorded sequence. Details including propagation of shock waves and surface changes during impact can be visualized using the feature.
Line Profile	A line profile representing grey levels along a line drawn across any region of the image is displayed. In live mode the Line Profile can be used to ensure optimum image focus is achieved.
Histogram	A histogram displaying grey levels within a user-defined image area is displayed. In live mode the Histogram can be used to ensure that optimum exposure levels are set for the scene being recorded.

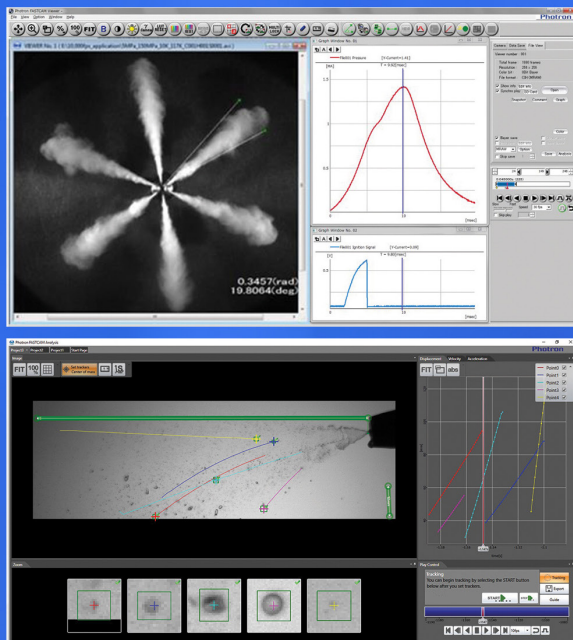

Photron FASTCAM Viewer:

Photron FASTCAM Viewer software (PFV) has been designed to provide an intuitive and feature rich user interface for the control of Photron high-speed cameras, data saving, image replay and simple motion analysis. Advanced operation menus provide access to features for advanced camera operation and image enhancement. Tools are provided to allow image calibration and easy measurement of angles and distances from image data. Also included are a C++ SDK and wrappers for LabView and MATLAB ®.

An optional software plug-in module provides synchronization between Photron high-speed cameras and data acquired through National Instruments data acquisition systems. Synchronized data captured by the DAQ system provides waveform information which can be viewed alongside high-speed camera images.

Photron FASTCAM Analysis:

PFV software allows image sequences to be exported directly to optional Photron FASTCAM Analysis (PFA) Motion Analysis software. This entry level Motion Analysis software with an on screen 'step by step guide' function provides automated tracking of up to 5 points using feature or correlation tracking algorithms for the automated analysis of motion within an image sequence.

FASTCAM ORION S40 Type 312K*							
Resolution	Frame Rate	32GB		64GB		128GB	
(h x v pixels)	Max fps	Frames	Time (sec)**	Frames	Time (sec)**	Frames	Time (sec)**
1280 x 1024	31,250	17,470	0.56	34,933	1.12	69,885	2.24
1280 x 896	31,250	17,457	0.56	39,923	1.28	79,869	2.56
1280 x 800	37,500	22,345	0.60	44,714	1.19	89,453	2.39
1280 x 640	48,000	27,931	0.58	55,893	1.16	111,817	2.33
1280 x 512	56,250	34,914	0.62	69,866	1.24	139,711	2.49
1024 x 1024	37,500	21,821	0.58	43,666	1.16	87,537	2.33
1024 x 768	50,000	29,095	0.82	58,222	1.16	116,476	2.33
1024 x 512	62,500	43,642	0.70	87,333	1.40	174,714	2.80
896 x 896	50,000	28,501	0.57	57,034	1.14	114,099	2.28
896 x 800	50,000	31,921	0.64	63,878	1.28	127,791	2.56
896 x 512	80,000	49,915	0.62	99,847	1.25	199,711	2.50
896 x 384	100,000	66,553	0.67	133,129	1.33	266,282	2.66
896 x 256	125,000	99,830	0.80	199,694	1.60	399,423	3.20
896 x 128	200,000	199,660	1.00	399,388	2.00	798,846	3.99
896 x 64	250,000	339,320	1.60	798,777	3.20	1,597,692	6.39
896 x 32	312,500	798,640	2.56	1,598,555	5.11	3,195,385	10.23

* Specifications subject to change without notice.

** Recording time is an estimate and may be different depending on recording conditions and settings.

Variable Region of Interest:

Region of Interest (ROI) or sub-windowing allows a user-specified portion of the sensor to be defined to capture images. By using a reduced portion of the image area, the frame rate at which images are recorded can be increased. The FASTCAM Orion S40 allows the ROI to be set in increments of 128 pixels horizontal and 32 pixels vertical.

External Frame Synchronization:

The FASTCAM Orion S40 can be fully synchronized with an external source to allow the timing of when each individual image is captured to be precisely referenced. The camera can be accurately synchronized to unstable frequencies allowing complex events such as combustion in rapidly accelerating or decelerating engines to be recorded and studied.

Record During Download Operation:

The FASTCAM Orion S40 recording memory can be divided into multiple active sections. The user can record an on-going event in one memory partition while at the same time downloading a previously recorded image sequence in order to improve workflow and optimize camera operation.

Mechanical and Environmental Specifications

Mechanical

Lens Mount	F-mount (G-type lens compatible) Optional lens mounts include C-mount and Canon EF remote control mount.
Camera Mountings	3/8 - 16 UNC, 1/4 - 20 UNC & 4 x M6 (base and side), 2 x 1/4 - 20 UNC (top)

External Dimensions

Camera Body (excluding protrusions)	267mm (H) x 182mm (W) x 93.6mm (D) 10.5" (H) x 7.2" (W) x 3.7" (D)
--	---

Weight

Camera Body	4.07kg (10.4lbs)
-------------	------------------

Environmental

Operating Temperature	0 to 40C, 32° to 104°F
Storage Temperature	-20 to 60C, -4° to 140°F
Humidity	85% or less (non-condensing)
Operational Shock	30G, 10 times, 6-axes

Power

AC Power (with supplied adapter)	100 to 240V, 50 to 60Hz
DC Power (primary input)	22 to 32V, 300VA

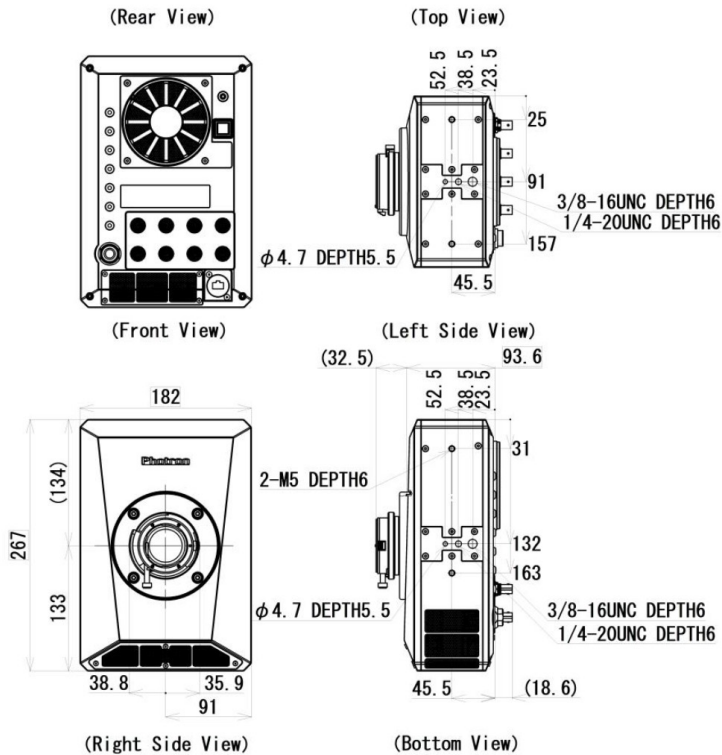

Nikon G-Type Compatible Lens Mount:

The FASTCAM Orion S40 camera is equipped with an objective lens mount compatible with readily available Nikon G-type lenses. Controls provided within the lens mount allow the control of lens aperture on lenses without external iris control.

Optional C-Mount and Canon EF Lens Mounts:

In addition to the standard Nikon G type lens adapter, all FASTCAM Orion S40 models support an optional C-mount lens adapter and an optional Canon EF lens adapter which, through Photron FASTCAM Viewer (PFV), not only enables remote operation of lens focus and aperture but also adds Auto-Focus capability.

Operation Environments:

The FASTCAM Orion S40 camera has been extensively tested to ensure operation for extended periods in ambient temperatures up to 40C.

Versatile Mounting of Camera:

The FASTCAM Orion S40 has mounting positions on all four sides. This permits the camera to be rotated through 90 degrees for those applications requiring maximum resolution with a vertical aspect ratio e.g. tensile testing.

Specifications subject to change without notice.

PHOTRON USA, INC.
9520 Padgett Street, Suite 110
San Diego, CA 92126
USA

Tel: 858.684.3555 or 800.585.2129
Fax: 858.684.3558
Email: image@photron.com
www.photron.com

PHOTRON EUROPE LIMITED
The Barn, Bottom Road
West Wycombe
Bucks. HP14 4BS
United Kingdom

Tel: +44 (0) 1494 481011
Fax: +44 (0) 1494 487011
Email: image@photron.com
www.photron.com

PHOTRON (Shanghai)
Room 20C, Zhao-Feng
World Trade Building
No. 369, JiangSu Road
Chang Ning District
Shanghai, 200050 China
Tel: +86 (21) 5268-3700
Fax: +86 (21) 5268-3702
Email: info@photron.cn
www.photron.cn

PHOTRON LIMITED
21F, Jinbocho Mitsui Bldg.
1-105 Kanda Jimbocho
Chiyoda-ku, Tokyo 101-0051
Japan

Tel: +81 (3) 3518-6271
Fax: +81 (3) 3 3518-6279
Email: image@photron.co.jp
www.photron.co.jp